

Product Catalogue **Freestanding Appliances**

**Miele**





<b>Laundry Care</b>	p. 3 – 7
<b>Dish &amp; Glass Care</b>	p. 8 – 10
<b>Food &amp; Beverage</b>	p. 11 – 13
<b>Cooling</b>	p. 14 – 19
<b>Floor Care</b>	p. 20 – 23
<b>Technical Information Charts</b>	p. 24 – 31

Superior Laundry Care

- Miele's unique Honeycomb drum with up to 6 kg capacity.
- Special Programmes: Handwash and Silks

Peace of mind:

- Unsurpassed Miele Quality
- Patented automatic programmes for ultimate convenience



**W 1513 Novotronic Washing Machine**



ENERGY EFFICIENCY A+  
WASH PERFORMANCE A  
SPIN EFFICIENCY B

**DESIGN**

Straight fascia  
5 kg drum capacity  
Extra large door opening  
Enamel front with powder coated sides  
H x W x D: 85 x 59.5 x 63.4 cm

**CONTROLS**

Single programme selector dial  
programme sequence indicator  
time left display  
PC update facility

**SPECIAL PROGRAMMES**

Cottons, Minimum iron, Delicates, Automatic, Separate rinse, Drain/Spin, Starch, Handwashable woollens, Silks

**ADDITIONAL FUNCTIONS**

Water plus, short, pre-wash

**SPIN**

400–1300 rpm spin speeds  
rinse hold & without spin

**SAFETY FEATURES**

Child resistant controls  
water control system  
check water inlet & drain indicators,  
detergent overdosing indicator

**CONSUMPTION**

45 litre water

**W 526 Novotronic Washing Machine**



ENERGY EFFICIENCY A+  
WASH PERFORMANCE A  
SPIN EFFICIENCY B

**DESIGN**

Straight fascia  
5 kg drum capacity  
Extra large door opening  
Direct enamel casing  
H x W x D: 85 x 59.5 x 58 cm

**CONTROLS**

Single programme selector dial  
programme sequence indicator  
time left display  
PC update facility

**SPECIAL PROGRAMMES**

Cottons, Minimum iron, Delicates, Automatic, Separate rinse, Drain/Spin, Starch, Quickwash, Handwashable woollens, Silks

**ADDITIONAL FUNCTIONS**

Water plus, short, pre-wash, soak

**SPIN**

400–1400 rpm spin speeds  
rinse hold & without spin

**SAFETY FEATURES**

Child resistant controls  
water control system  
check water inlet & drain indicators,  
detergent overdosing indicator

**CONSUMPTION**

45 litre water, 0.85 kWh electricity

**W 3240 Honeycomb Care Washing Machine**



ENERGY EFFICIENCY A+  
WASH PERFORMANCE A  
SPIN EFFICIENCY B

**DESIGN**

Straight fascia  
Unique Miele Honeycomb Drum with  
6 kg capacity  
Extra large door opening  
Direct enamel casing  
H x W x D: 85 x 59.5 x 58 cm

**CONTROLS**

Single programme selector dial  
programme sequence indicator  
time left display  
PC update facility

**SPECIAL PROGRAMMES**

Cottons, Minimum iron, Dark, Denims, Shirt, Delicates, Automatic, Separate rinse, Drain/Spin, Starch, Express, Quickwash, Handwashable woollens, Silks

**ADDITIONAL FUNCTIONS**

Water plus, short, pre-wash, soak

**SPIN**

400–1400 rpm spin speeds  
rinse hold & without spin

**SAFETY FEATURES**

Child resistant controls  
water control system  
check water inlet & drain indicators,  
detergent overdosing indicator

**CONSUMPTION**

49 litre water, 1.02 kWh electricity

**W 3364 Honeycomb Care Washing Machine**



ENERGY EFFICIENCY A+  
WASH PERFORMANCE A  
SPIN EFFICIENCY A

**DESIGN**

Straight fascia  
Unique Miele Honeycomb Drum with  
6 kg capacity  
Extra large door opening  
Direct enamel casing  
H x W x D: 85 x 59.5 x 58 cm

**CONTROLS**

Single programme selector dial  
programme sequence indicator  
delay start with time left display  
PC update facility

**SPECIAL PROGRAMMES**

Cottons, Minimum iron, Dark, Denims, Shirt, Delicates, Automatic, Separate rinse, Drain/Spin, Starch, Express, Quickwash, Handwashable woollens, Silks

**ADDITIONAL FUNCTIONS**

Water plus, short, pre-wash, soak

**SPIN**

400–1600 rpm spin speeds  
rinse hold & without spin

**SAFETY FEATURES**

Child resistant controls  
water control system  
check water inlet & drain indicators,  
detergent overdosing indicator

**CONSUMPTION**

49 litre water, 1.02 kWh electricity

**W 3574 WPS "Allerwash" Honeycomb Care Washing Machine**



ENERGY EFFICIENCY A  
WASH PERFORMANCE A  
SPIN EFFICIENCY A

**DESIGN**

Straight fascia  
Unique Miele Honeycomb Drum with 6 kg capacity  
Extra large door opening  
Direct enamel casing  
H x W x D: 85 x 59.5 x 58 cm

**CONTROLS**

Single programme selector dial  
programme sequence indicator  
time left display programme delay up to 24 hrs  
PC update facility

**SPECIAL PROGRAMMES**

Cottons universal, Cottons Hygiene, Pillows Hygiene, Minimum iron, Dark, Denims, Shirt, Delicates, Automatic, Separate rinse, Drain/Spin, Starch, Express, Quickwash, Handwashable woollens, Silks, First wash

**ADDITIONAL FUNCTIONS**

Water plus, short, pre-wash, soak, intensive, rinse plus

**SPIN**

400–1600 rpm spin speeds  
rinse hold & without spin

**SAFETY FEATURES**

Child resistant controls  
water control system  
check water inlet & drain indicators,  
detergent overdosing indicator

**CONSUMPTION**

69 litre water, 1.14 kWh electricity

**W 3985 WPS Navitronic Honeycomb Care Washing Machine**



ENERGY EFFICIENCY A+  
WASH PERFORMANCE A  
SPIN EFFICIENCY A

**DESIGN**

Angled fascia  
Unique Miele Honeycomb Drum with 6 kg capacity  
Extra large door opening  
Large clear text display  
Halogen drum lighting  
Direct enamel casing  
H x W x D: 85 x 59.5 x 58 cm

**CONTROLS**

Navitronic controls with "Jogshuttle"  
programme sequence indicator  
time left display programme delay up to 24 hrs  
PC update facility

**SPECIAL PROGRAMMES**

Cottons universal, Cottons Hygiene, Minimum iron, Dark, Denims, Shirt, Delicates, Automatic, Separate rinse, Drain/Spin, Starch, Express, Quickwash, Handwashable woollens, Silks, Outer wear

**ADDITIONAL FUNCTIONS**

Water plus, short, pre-wash, soak, intensive,

**SPIN**

400–1800 rpm spin speeds  
rinse hold & without spin

**SAFETY FEATURES**

Child resistant controls  
water control system  
check water inlet & drain indicators,  
detergent overdosing indicator

**CONSUMPTION**

42 litre water, 0.85 kWh electricity

**W 3923 WPS stainless steel WASHER AND DRYER STACKING KITS**



ENERGY EFFICIENCY A+  
WASH PERFORMANCE A  
SPIN EFFICIENCY A

**DESIGN**

Angled fascia / LCD plus display  
Unique Miele Honeycomb Drum with 6 kg capacity  
Extra large door opening with LED lighting  
H x W x D: 85 x 59.5 x 58 cm

**CONTROLS**

Single programme selector dial  
programme sequence indicator  
time left display programme delay up to 24 hrs

**SPECIAL PROGRAMMES**

Cottons, Minimum iron, Delicates, Silks, Woollens, Automatic, Shirts, Denim, Express, Hygiene, Starch, Spin, Dark garments, Curtains, Pillows, Sportswear, Outerwear, Proofing, Separate rinse

**ADDITIONAL FUNCTIONS**

Short, Pre-wash, Soak, Water plus, Rinse hold, Extra rinse

**SPIN**



Maximum spin speed 1600 rpm

**SAFETY FEATURES**

Child resistant controls  
Waterproof system  
In operation/system lock  
detergent overdosing indicator

**CONSUMPTION**

47 litre water, 1.02 kWh electricity

Tumble-dryer	T 200/4000 series	T 200/4000/8000 series
WTV	WTV 406 LW <sup>1)</sup> 	WTV 407 LW <sup>1)</sup> 
Washing machine	W 500/3000 series with straight fascia	W 500/3000 series with angled fascia

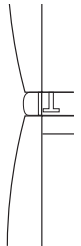
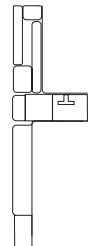
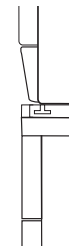
T 7000 series	T 4000 "i" and decor models	T 200/4000/7000/8000 series
WTV 414 LW <sup>1)</sup> 	WTV 410 LW <sup>2)</sup> 	WTV 412 LW <sup>3)</sup> 
W 1000 series with	W 500/3000 series with straight fascia	W 500/3000 series with angled fascia

<sup>1)</sup> with pull-out shelf

<sup>2)</sup> stainless steel fascia available to co-ordinate stainless steel appliances

<sup>3)</sup> without pull-out shelf

**T 7634 Novotronic Vented Tumble Dryer**



ENERGY EFFICIENCY C

**DESIGN**

Straight fascia  
5 kg drum capacity  
Extra large door opening  
Enamel front with powder coated sides  
H x W x D: 85 x 59.5 x 58 cm

**CONTROLS**

Single programme selector dial  
programme sequence indicator  
Delay start with time left display  
PC update facility

**SPECIAL PROGRAMMES**

7 drying programmes including automatic, smoothing and woollens handcare

**T 7644 C Novotronic Condenser Tumble Dryer**

Same features as T 7634 vented dryer, but as condenser version

ENERGY EFFICIENCY B

**T 4162 Honeycomb Care Vented Tumble Dryer**



ENERGY EFFICIENCY C

**DESIGN**

Straight fascia  
6 kg honeycomb drum capacity  
Extra large door opening  
Enamel front with powder coated sides  
H x W x D: 85 x 59.5 x 58 cm

**CONTROLS**

Single programme selector dial  
programme sequence indicator  
PC update facility

**SPECIAL PROGRAMMES**

7 sensor drying programmes including automatic, smoothing and woollens handcare

**T 4262 C Honeycomb Care Condenser Tumble Dryer**

Same features as T 4162 vented dryer, but as condenser version

ENERGY EFFICIENCY C

**T 4462 C Honeycomb Care Condenser Tumble Dryer**



ENERGY EFFICIENCY B

**DESIGN**

Straight fascia  
6 kg honeycomb drum capacity  
Extra large door opening  
Enamel front with powder coated sides  
H x W x D: 85 x 59.5 x 58 cm

**CONTROLS**

Single programme selector dial  
programme sequence indicator  
programme delay up to 24 hrs  
time left display  
PC update facility  
Air cooling system

**SPECIAL PROGRAMMES**

10 sensor drying programmes including automatic, shirts, denims, delicates, smoothing and woollens handcare

**SAFETY FEATURES**

Empty condenser water container indicator  
Fully electronic child resistant controls  
Electronic system lock

**T 4464 C "Allerdry" Honeycomb Care Condenser Dryer**



ENERGY EFFICIENCY C

**DESIGN**

Straight fascia  
6 kg Honeycomb drum capacity  
Extra large door opening  
Enamel front with powder coated sides  
H x W x D: 85 x 59.5 x 58 cm

**CONTROLS**

Single programme selector dial with light ring  
Programme sequence indicator  
Programme delay up to 24 hrs  
Time left display  
PC update facility  
Air cooling system

**SPECIAL PROGRAMMES**

10 sensor drying programmes including Allerdry cottons; minimum iron; pillows; timed drying hygiene smoothing and woollens handcare

**SAFETY FEATURES**

Empty condenser water container indicator light  
Fully electronic child resistant controls  
Clean out airways indicator light  
Change filter indicator light  
Electronic system lock

**T 8623 C stainless steel condenser tumble dryer**



ENERGY EFFICIENCY B

**DESIGN**

Angled fascia with LCD plus display  
6 kg Honeycomb drum with lighting  
Extra large door opening  
Enamel front with powder coated sides  
H x W x D: 85 x 59.5 x 58 cm

**CONTROLS**

Single programme selector dial  
Programme sequence indicator  
Programme delay up to 24 hrs  
Time left display  
PC update facility  
Air cooling system

**SPECIAL PROGRAMMES**

10 sensor drying programmes including  
Cottons, Minimum iron, Delicates, Automatic,  
Shirts, Denim, Woollens handcare, Silks handcare,  
Smoothing, Hygiene, Timed drying: Warm air,  
Cool air  
Extra options: Low temperature, Short, Anti-crease  
Buzzer

**SAFETY FEATURES**

Empty condenser water container indicator light  
Fully electronic child resistant controls  
Clean out airways indicator light  
Change filter indicator light  
In operation/System lock

**T 8685 C Navitronic Honeycomb Care Condenser Dryer**



ENERGY EFFICIENCY B

**DESIGN**

Angled fascia with aluminium look finish  
6 kg Honeycomb drum capacity  
Extra large door opening  
Drum lighting  
Enamel front with powder coated sides  
H x W x D: 85 x 59.5 x 58 cm

**CONTROLS**

Jogshuttle control for programme selection plus  
shortcut buttons for favourites and extra options  
Large clear text navigation display  
Programme sequence indicator  
Programme delay up to 24 hrs  
Time left display  
PC update facility  
Air cooling system

**SPECIAL PROGRAMMES**

14 sensor drying programmes including  
Automatic; Outerwear; Denim and Shirts  
programmes;  
Anti crease phase; woollens handcare and  
smoothing

**SAFETY FEATURES**

Empty condenser water container indicator  
Fully electronic child resistant controls  
Clean out airways indicator  
Electronic system lock

**WT 2670 Honeycomb Care Washer Dryer**



ENERGY EFFICIENCY A+  
WASH PERFORMANCE A

**DESIGN**

Straight fascia  
Unique Miele honeycomb drum with 5 kg wash  
capacity and 2.5 kg dry capacity  
Extra large door opening  
Direct enamel casing  
H x W x D: 85 x 59.5 x 58 cm

**CONTROLS**

Single programme selector dial with light ring  
Programme sequence indicator light  
Programme delay up to 24 hrs  
Time left display  
PC update facility  
Air cooling system  
Unique load size indicator

**SPECIAL PROGRAMMES**

17 Wash Programmes and 14 sensor drying  
programmes including Sportswear; Reproofing  
and handcare woollens

**SPIN SPEEDS**

400–1600 rpm  
rinse hold & without spin

**SAFETY FEATURES**

Empty condenser water container indicator  
Fully electronic child resistant controls  
Electronic system lock

**B 890 Rotary Iron**



**DESIGN**

Folds away for minimum storage space  
85 cm wide heater plate  
Free roller end

**SAFETY FEATURES**

Automatic finger guard

**FEATURES**

Aluminium heater plate  
Three heater elements with special thermostat  
Five choices of roller speed  
Wide foot control bar

**EASE OF USE**

Laundry table to hold in soft folds  
Easy to use controls  
Comfortable working position with generous leg  
room

**DIMENSIONS**

H x W x D: 96 x 98.5 x 38 cm

**B 895 Steam Rotary Iron**

Same features as B 890, but with Steam function

Dish and Glass Care



Miele's unique cutlery tray and highly versatile baskets

- Superior Dish and Glass care
- *Glasscare and intelligent sensor system*

## G 975 PLUS Freestanding Dishwasher



### DESIGN

60 cm wide model  
Available in White only  
H x W x D: 84.7–88.7 x 59.8 x 60 cm

### CONTROLS

Fully electronic Novotronic controls  
Single dial programme selection  
PC update facility

### PROGRAMME SELECTION

6 programmes: Intensive 75°C, Universal 55°C,  
Universal Plus 55°C, Normal 50°C, Economy, Pre-Wash

### CAPACITY

12 place setting

### SOUND LEVEL

51 dB (A) re 1 pW in situ

### CONSUMPTION

13 litre water and 1.05 kWh electricity in the Economy programme

### SPECIAL FEATURES

Cutlery basket  
Height adjustable upper basket  
Versatile lower basket  
Waterproof anti leak system

## G 1040 Freestanding Dishwasher



### DESIGN

60 cm wide model  
Available in White only  
H x W x D: 84.5–88 x 59.8 x 60 cm

### CONTROLS

Fully electronic Novotronic controls  
Single dial programme selection  
PC update facility

### PROGRAMME SELECTION

6 programmes: Quick wash 40°C, Light 50°C,  
Sensor Wash 55–65°C, Energy Save, Pots & Pans 75°C, Pre-Wash

### CAPACITY

12 place setting

### SOUND LEVEL

48 dB (A) re 1 pW in situ

### CONSUMPTION

13 litre water and 1.05 kWh electricity in the Economy programme

### SPECIAL FEATURES

Cutlery basket  
Height adjustable upper basket  
Versatile lower basket  
ECO Sensor  
Waterproof anti leak system

## G 1140 SC Freestanding Dishwasher



### DESIGN

60 cm wide model  
Available in White only  
H x W x D: 84.5–88 x 59.8 x 60 cm

### CONTROLS

Fully electronic controls  
Touch button programme selection  
PC update facility

### PROGRAMME SELECTION

6 programmes: Quick wash 40°C, Light 50°C,  
Sensor Wash 55–65°C, Energy Save, Pots & Pans 75°C, Pre-Wash

### CAPACITY

12 place setting

### SOUND LEVEL

48 dB (A) re 1 pW in situ

### CONSUMPTION

13 litre water and 1.05 kWh electricity in the Economy programme

### SPECIAL FEATURES

Unique Cutlery Tray  
Height adjustable upper basket  
Versatile lower basket  
ECO Sensor  
Waterproof anti leak system

**G 1220 SC Freestanding Dishwasher****DESIGN**

60 cm wide model  
Available in White only  
H x W x D: 84.5–88 x 59.8 x 60 cm

**CONTROLS**

Fully electronic controls  
Touch button programme selection  
PC update facility  
Programme delay with time left display

**PROGRAMME SELECTION**

6 programmes: Quick wash 40°C, Sensor Wash, Sensor Wash Gentle, Energy Save, Pots & Pans 75°C, Pre-Wash

**CAPACITY**

12 place setting

**SOUND LEVEL**

48 dB (A) re 1 pW in situ

**CONSUMPTION**

13 litre water and 1.05 kWh electricity in the Economy programme

**SPECIAL FEATURES**

Unique Cutlery Tray  
Height adjustable upper basket  
Versatile lower basket  
ECO Sensor  
Waterproof anti leak system

**G 1230 SC Freestanding Dishwasher****DESIGN**

60 cm wide model  
Available in Stainless Steel only  
H x W x D: 84.5-88 x 59.8 x 60 cm

**CONTROLS**

Fully electronic controls  
Touch button programme selection  
PC Update facility  
Programme delay with time left display

**PROGRAMME SELECTION**

6 programmes: Sensor wash, Quick wash 40°C, Sensor wash gentle, Energy save, Pots & pans 75°C, Pre-Wash

**CAPACITY**

12 place setting

**SOUND LEVEL**

48 dB (A) re 1 pW in situ

**CONSUMPTION**

13 litres water, 1.05 kWh electricity in Energy Save

**SPECIAL FEATURES**

Unique Cutlery Tray  
Height adjustable upper basket  
Versatile lower basket  
ECO Sensor  
Waterproof anti leak system



Miele's unique external steam generator

Simple and Efficient

Food & Beverage

**DG 1050 Freestanding Steam Oven**



**DESIGN**

Available in Stainless Steel only  
 Flush full-width tinted glazed door  
 20 litre stainless steel oven interior with 3 cooking levels  
 External steam generator  
 50 cm wide counter top model  
 H x W x D: 38.2 x 49.5 x 32.7 cm

**OPERATING MODES**

Cooking, reheating and defrosting by time and temperature  
 Time selectable from 1 min to 4 h 59 min  
 Temperatures adjustable between 40°C and 100°C in 5°C increments

**ELECTRONIC CONTROLS**

Electronic control dial with turn and press mechanism  
 Display for temperatures and time, descaling reminder and water level indication  
 Programmable cooking duration with automatic switch-off

**SAFETY FEATURES**

Enhanced vapour cooling and vented system door contact switch

**ACCESSORIES**

2 x 0.9 litre net capacity perforated stainless steel containers  
 Rack, drip tray, water tank with integrated heating element

**M 8201 Freestanding Microwave Oven**



**DESIGN**

Available in stainless steel only  
 26 litre stainless steel interior  
 H x W x D: 45 x 56 x 50 cm

**FEATURES**

Grill integrated into roof of cavity  
 Electronic timer and clock display  
 LED display for time of day and various functions  
 Rotary selector dial for microwave power, grill and combination programmes  
 Rotary selector dial for time and weight  
 Buttons for additional functions and automatic programmes  
 Interior light

**OUTPUT**

7 power levels: 80, 150, 300, 450, 600, 750, 900 W  
 Grill output 800 W

**FUNCTIONS**

Quickstart with 30, 60, 120 seconds  
 Microwave and grill can be used individually or in combination  
 10 automatic programmes for defrosting, cooking and reheating  
 Timer 10 seconds to 90 minutes  
 Automatic warming function

**DGGL 2 Steamer Insert**



1.5 L Perforated stainless steel container

**DGG 2 Steamer Insert**



2.5 L Solid stainless steel container

**DGG 3 Steamer Insert**



4.0 L Solid stainless steel container

**DGGL 4 Steamer Insert**



4.0 L Perforated stainless steel container

**DGGL 5 Steamer Insert**



2.5 L Perforated stainless steel container

**DGGL 6 Steamer Insert**



4.0 L Perforated stainless steel container

**DGG 7 Steamer Insert**



4.0 L Solid stainless steel container

**DGD Steamer Insert**



Lid for solid stainless steel containers DGG 2 and DGG 7

## CVA 2650 Freestanding NESPRESSO Coffee Machine



### DESIGN

Available in Stainless Steel only  
Black interior  
Door hinged left  
LED illumination of working area  
50 cm wide freestanding counter top model  
H x W x D: 37.2 x 49.5 x 32.4 cm

### PREPARATION OPTIONS

Removable capsule magazine for 20 capsules of up to 5 different types  
4 choices of cup size: Espresso, double espresso, coffee, double coffee  
Water quantity can be programmed individually for each cup  
Programme up to 4 additional user profiles to suit individual preferences

### ELECTRONIC CONTROLS

2 graphic displays with clear text and up to 15 language options  
2 rotary dials with turn and push function  
Programmable on/off time

### FEATURES

Automatic rinse and cleaning programme  
Programmable water hardness setting  
2 stainless steel through-flow water heaters  
Cappuccinatore jug for frothing milk  
1.5 litre capacity fresh water container  
Large capacity waste container for 25 spent capsules  
Safety lock  
Refill reminder for: Capsules, Fresh water, Descaling programme, empty drip tray, empty capsule container

### CVC 26 Cappuccinatore



Cappuccinatore - A system designed for perfectly frothed milk  
Froth milk in the jug or dispense frothed milk simultaneously straight into the cup  
Dishwasher safe

### GCEO insert



Dishwasher insert for cappuccinatore jug



Miele's Wine Cellar has an electronic temperature regulation between 5°C and 22°C to prevent temperature fluctuations

Cooling



Dynamic Cooling system to create a constant humidity level

Charcoal filter to prevent the wine from external odours



### K 8852 SD Refrigerator



### FN 4857 S Frost Free Freezer



### KFN 8452 SD Frost Free Fridge Freezer



### KTN 4352 SD ED Frost Free Fridge Freezer



#### DESIGN

Free standing model  
 Door hinged right, convertible  
 Softline door with aluminium coloured lever handle  
 Super cool button with indicator light  
 H x W x D: 184.1 x 60 x 63.2 cm

#### CAPACITY

Larder refrigerator with 398 l/ 14.1 cu ft usable space  
 Automatic defrosting  
 Dynamic cooling  
 Interior light with temperature regulator  
 8 high quality glass shelves, including 1 split shelf, 6 are height adjustable  
 4 fruit and vegetable compartments  
 Chrome bottle rack

#### DOOR INTERIOR

Dairy compartment  
 3 half racks, 2 bottle racks

#### DESIGN

Free standing model  
 Door hinged left, convertible  
 Softline door with aluminium coloured lever handle  
 Super Freeze button with indicator light  
 H x W x D: 184.1 x 60 x 63.2 cm

#### CAPACITY

4 star freezer with 257 l/ 9.1 cu ft usable space  
 Frost free system with Automatic defrost  
 Freezes 18 kg in 24 hrs  
 Digital temperature display with selector buttons  
 7 +1 non-tip sealed transparent drawers  
 Removable glass cold plate between drawers  
 2 cool packs, ice cube tray  
 Freezer tray  
 Frozen food marker system

#### DESIGN

Free standing model  
 Doors hinged right, convertible  
 Softline doors with aluminium coloured lever handle  
 Super freeze switch with indicator light  
 H x W x D: 180.6 x 60 x 63.2 cm

#### CAPACITY

Total capacity: 313 l/11.1 cu ft usable space  
 Fridge capacity: 224 l/8 cu ft usable space  
 Freezer capacity: 89 l/3.1 cu ft usable space

#### REFRIGERATOR

Automatic defrosting  
 Dynamic cooling  
 Interior light with temperature regulator  
 Fully enclosed evaporator  
 4 high quality glass shelves, including 1 split shelf, 3 are height adjustable  
 2 fruit and vegetable compartments  
 Versatile door fittings with bottle rack and covered dairy compartment

#### 4-STAR FREEZER

Frost Free system with automatic defrost  
 3 large non-tip sealed transparent drawers  
 Removable cold plate between 2 drawers  
 frozen food marker system  
 2 cool packs, ice cube tray  
 Freezes 14 kg in 24 hrs

#### DESIGN

Free standing model  
 Door hinged right, convertible  
 Stainless steel front with "soft close" metal lever handle  
 Super freeze switch with indicator light  
 H x W x D: 169 x 60 x 63 cm

#### CAPACITY

Total capacity: 284 l/10 cu ft usable space  
 Fridge capacity: 224 l/7.9 cu ft usable space  
 Freezer capacity: 60 l/2.1 cu ft usable space

#### REFRIGERATOR

Automatic defrosting  
 Dynamic cooling  
 Interior light with temperature regulator  
 Fully enclosed evaporator  
 5 high quality glass shelves, including 1 split shelf, 4 are height adjustable  
 2 fruit and vegetable compartments  
 Versatile door fittings with bottle rack and covered dairy compartment

#### 4-STAR FREEZER

Frost Free system with automatic defrost  
 Height adjustable rack  
 ice cube tray  
 Freezes 7 kg in 24 hrs

KF 8582 SD ED Fridge Freezer

**DESIGN**

Free standing model  
Doors hinged right, convertible  
Stainless steel front with soft close metal handle  
Super freeze switch with indicator light  
H x W x D: 184 x 75 x 63 cm

**CAPACITY**

Total capacity: 432 l/15.2 cu ft usable space  
Fridge capacity: 337 l/11.9 cu ft usable space  
Freezer capacity: 95 l/3.3 cu ft usable space

**REFRIGERATOR**

Automatic defrosting  
Dynamic cooling  
Interior light with temperature regulator  
Fully enclosed evaporator  
4 high quality glass shelves, including 1 split shelf, 3 are height adjustable  
3 wire bottle racks  
2 fruit and vegetable compartments  
Versatile door fittings with bottle rack and covered dairy compartment

**4-STAR FREEZER**

2 large non-tip sealed transparent drawers  
ice cube tray  
Freezes 8 kg in 24 hrs

KFN 8562 SD ED Frost Free Fridge Freezer

**DESIGN**

Free standing model  
Doors hinged right, convertible  
Stainless steel front with "soft close" metal lever handle  
Super freeze switch with indicator light  
H x W x D: 180.6 x 60 x 63.2 cm

**CAPACITY**

Total capacity: 313 l/11.1 cu ft usable space  
Fridge capacity: 224 l/8 cu ft usable space  
Freezer capacity: 89 l/3.1 cu ft usable space

**REFRIGERATOR**

Automatic defrosting  
Dynamic cooling  
Interior light with temperature regulator  
Fully enclosed evaporator  
4 high quality glass shelves, including 1 split shelf, 3 are height adjustable  
2 fruit and vegetable compartments  
Versatile door fittings with bottle rack and covered dairy compartment

**4-STAR FREEZER**

Frost Free system with automatic defrost  
3 large non-tip sealed transparent drawers  
Removable cold plate between 2 drawers  
frozen food marker system  
2 cool packs, ice cube tray  
Freezes 14 kg in 24 hrs

K 8952 SD ED Refrigerator

**DESIGN**

Free standing model  
Doors hinged right, convertible  
Stainless steel front with soft close metal handle  
Super freeze switch with indicator light  
H x W x D: 184.1 x 60 x 63.2 cm

**CAPACITY**

Larder refrigerator with 398 l/14.1 cu ft usable space

**REFRIGERATOR**

Automatic defrosting  
Dynamic cooling  
Interior light with temperature regulator  
Fully enclosed evaporator  
7 high quality glass shelves, including 1 split shelf, 6 are height adjustable  
Chrome bottle rack  
4 fruit and vegetable compartments

**DOOR INTERIOR**

Versatile door fittings with 2 bottle racks, 3 half racks and dairy compartment

**FN 4957 SED Frost Free Freezer**



ENERGY EFFICIENCY A

**KFN 8701 SE ED Frost Free Freezer with StayFresh**



ENERGY EFFICIENCY A

**KWFN 8706 SE ED Freezer with Wine Cooler**



ENERGY EFFICIENCY A

**DESIGN**

Free standing model  
Door hinged left, convertible  
Stainless steel front with soft close metal lever handle  
Super Freeze button with indicator light  
H x W x D: 184.1 x 60 x 63.2 cm

**CAPACITY**

4 star freezer with 257 l/9.1 cu ft usable space  
Frost free system with Automatic defrost  
Freezes 18 kg in 24 hrs  
Digital temperature display with selector buttons  
7 +1 non-tip sealed transparent drawers  
Removable glass cold plate between drawers  
2 cool packs, ice cube tray  
Freezer tray  
Frozen food marker system

**DESIGN**

Free standing model  
Doors hinged left, convertible  
Stainless steel front with soft close metal handle  
Super freeze switch with indicator light  
Super cool button with indicator light  
H x W x D: 184.1 x 60 x 63.2 cm

**CAPACITY**

Total capacity: 249 l/8.8 cu ft usable space  
StayFresh zone capacity: 130 l/4.6 cu ft usable space  
Freezer capacity: 119 l/4.2 cu ft usable space

**STAYFRESH ZONE**

Automatic defrosting  
Interior light with temperature regulator  
Fully enclosed evaporator  
2 high quality glass shelves  
Chrome bottle rack  
1 dry and 1 humidity controlled Stayfresh compartment  
Versatile door fittings with bottle rack and covered dairy compartment

**4-STAR FREEZER**

2 small non-tip sealed transparent drawers  
3 large non-tip sealed transparent drawers  
Removable glass cold plate between drawers  
2 cool packs, ice cube tray  
Frozen food marker system  
Freezes 14 kg in 24 hrs

**DESIGN**

Free standing model  
Doors hinged left convertible  
Stainless steel front with soft close metal handle  
Super freeze switch with indicator light  
H x W x D: 184.1 x 60 x 63.2 cm

**CAPACITY**

Total capacity: 263 l/9.3 cu ft usable space  
Wine Cooler Capacity: 114 l/5.1 cu ft usable space  
Freezer capacity: 119 l/4.2 cu ft usable space

**WINE COOLER**

Frost free system with automatic defrosting  
Dynamic cooling/humidity button with indicator light  
5 removable wooden shelves with decor strips for 40 bottles  
Charcoal filter

**4-STAR FREEZER**

Frost free system with automatic defrost  
2 small non-tip sealed transparent drawers  
3 large non-tip sealed transparent drawers  
Removable glass cold plate between drawers  
2 cool packs  
ice cube maker (1.1 kg in 24 hrs)  
Frozen food marker system  
Freezes 14 kg in 24 hrs

**KWL 4712 SG ED Wine Storage Unit****DESIGN**

Freestanding model  
 Doors hinged right, convertible  
 Stainless steel casing with full height glass door  
 Light grey inner cabinet  
 Interior lighting  
 H x W x D: 165.8 x 66 x 68.3 cm

**CAPACITY**

Total Capacity: 162 bottles (0.75 l Bordeaux)

**WINE COOLER**

Electronic soft touch controls concealed behind the door  
 Temperature regulation from +5°C to + 22°C using +/- controls  
 Digital temperature display  
 Dynamic cooling  
 Audible warning tone with OFF button  
 6 storage levels including 5 height adjustable acacia wood shelves  
 Fresh air intake via an active charcoal filter  
 Cabinet heater for low ambient temperatures  
 Constant humidity levels up to 70%  
 Door lock

**KWT 4974 SG ED Wine Conditioning Unit****DESIGN**

Freestanding model  
 Doors hinged right, convertible  
 Stainless steel casing with full height glass door  
 Light grey inner cabinet  
 Interior lighting  
 H x W x D: 185.5 x 66 x 67.4 cm

**CAPACITY**

Total Capacity: 162 bottles (0.75 l Bordeaux)  
 – 36 in the upper zone, 45 in the middle zone and 62 in the lower zone

**WINE COOLER**

Electronic soft touch controls concealed behind the door  
 Temperature regulation from +3°C to 20°C using +/- controls  
 Digital temperature display  
 Dynamic cooling  
 Audible warning tone with OFF button  
 13 storage levels including 5 height adjustable acacia wood shelves  
 2 in the upper zone, 3 in the middle zone and 5 in the lower zone  
 Fresh air intake via an active charcoal filter  
 Cabinet heater for low ambient temperatures  
 Constant humidity levels up to 70%  
 Door lock



KFN 8996 SDE ED-1 Frost Free Fridge Freezer

**DESIGN**

Free standing model  
 Doors hinged right, convertible  
 Stainless steel front with soft close metal handle  
 Super freeze switch with indicator light  
 Super cool button with indicator light  
 Two independently controlled compressors  
 H x W x D: 200 x 75 x 63 cm

**CAPACITY**

Total capacity: 439 l/15.5 cu ft usable space  
 Fridge capacity: 320 l/11.3 cu ft usable space  
 Freezer capacity: 119 l/4.2 cu ft usable space

**REFRIGERATOR**

Dynamic cooling  
 Automatic defrosting  
 Interior LED lighting illuminating glass shelves and door shelves  
 Fully enclosed evaporator  
 5 high quality glass shelves including 1 split shelf, 4 are height adjustable  
 Chrome bottle rack  
 1 fruit and vegetable compartment  
 Versatile door fittings with bottle rack, 2 half racks and covered dairy compartment

**4-STAR FREEZER**

Frost free system with automatic defrosting  
 2 small non-tip sealed transparent drawers  
 2 large non-tip sealed transparent drawers  
 Removable glass cold plate between drawers  
 2 cool packs  
 Ice cube maker (1.1 kg/24 hrs)  
 Frozen food marker system  
 Freezes 10 kg in 24 hrs



KFNS 3929 SDEed American Style Fridge Freezer

**DESIGN**

American Style – Free standing model with  
 Stainless steel casing  
 Three independently controlled compressors  
 (Wine/Fridge/Freezer)  
 H x W x D: 187 x 121 x 68.4 cm

**CAPACITY**

Total capacity: 600 l/21.2 cu ft usable space  
 Fridge capacity: 237 l/11.3 cu ft usable space  
 StayFresh zone capacity: 100 l/3.5 cu ft usable space  
 Wine cellar capacity: 144 l/5.1 cu ft usable space  
 Freezer capacity: 119 l/4.2 cu ft usable space  
 Wine storage/Freezer with two independently controlled compressors on left hand side

**REFRIGERATOR**

Automatic defrosting  
 Fully enclosed evaporator  
 5 high quality glass shelves including 1 split shelf, 4 are height adjustable  
 2 fruit and vegetable compartment  
 Versatile door fittings with bottle rack, 2 half racks and covered dairy compartment  
 Interior light

**STAYFRESH ZONE**

1 dry StayFresh compartment with up to 45% humidity  
 2 humidity controlled StayFresh compartments, can be regulated between 45% and 90% humidity

**WINE CELLAR**

Frost free system with automatic defrosting  
 5 shelves for 40 bottles, charcoal filter

**4-STAR FREEZER**

Frost free system with automatic defrosting  
 2 small non-tip sealed transparent drawers  
 2 large non-tip sealed transparent drawers  
 Removable glass cold plate between drawers  
 Ice cube maker (1.1 kg/24 hrs)  
 Freezes 10 kg in 24 hrs

Floor Care



Convenient and Compact Design

Flexible Maneuverability





S 4211 - Lemon Yellow

Designed and tested for an average life of 20 years

#### **CONTROLS**

Electronic suction power regulation using rotary dial  
6 power settings including economy setting

#### **PERFORMANCE**

2000 W motor – powerful but quiet

#### **FILTER SYSTEM**

Super Air Clean filter  
3.5 litre self-sealing dustbag – Type F/J/M

#### **FEATURES**

Stainless steel height adjustable telescopic suction tube  
Standard floorhead SBD 450-3 with 360 comfort swivel joint  
Operating radius 9 m  
3 smooth running 360 castor wheels  
Park system for floorhead at rear of cleaner  
Storage system at either side for easy carrying  
Automatic cable rewind

#### **SAFETY**

Bumper strip to protect cleaner and furniture  
Change dustbag indicator  
Automatic cut-out on overheating



S 4211 Parquet & Co - Electric Blue Metallic

Designed and tested for an average life of 20 years

#### **CONTROLS**

Electronic suction power regulation using rotary dial  
6 power settings including economy setting

#### **PERFORMANCE**

2000 W motor – powerful but quiet

#### **FILTER SYSTEM**

Super Air Clean filter  
3.5 litre self-sealing dustbag – Type F/J/M

#### **FEATURES**

Stainless steel height adjustable telescopic suction tube  
Standard floorhead SBD 450-3 with 360 comfort swivel joint  
Parquet brush SBB Parquet-3  
Operating radius 9 m  
3 smooth running 360 castor wheels  
Park system for floorhead at rear of cleaner  
Storage system at either side for easy carrying  
Automatic cable rewind

#### **SAFETY**

Bumper strip to protect cleaner and furniture  
Change dustbag indicator  
Automatic cut-out on overheating

S 5210 – Deep Black



Designed and tested for an average life of 20 years

**CONTROLS**

Electronic suction power regulation using rotary dial

6 power settings including "Silence" setting

**PERFORMANCE**

2200 W motor – powerful but quiet

**FILTER SYSTEM**

Super Air Clean filter

4.5 litre self-sealing dustbag – Type GN

**FEATURES**

Stainless steel height adjustable telescopic suction tube

Standard floorhead SBD 285-3 with retractable brushes for edge to edge cleaning of carpets and hard floors and 360° comfort swivel joint  
Operating radius 10 m

Park system for floorhead at rear of cleaner  
Storage system at either side for easy carrying  
Automatic cable rewind with comfort touch

**SAFETY**

Bumper strip to protect cleaner and furniture  
Change dustbag indicator  
Automatic cut-out on overheating

S 5280 – Silver Metallic



Designed and tested for an average life of 20 years

**CONTROLS**

Electronic suction power regulation using rotary dial

6 power settings including "Silence" setting

**PERFORMANCE**

2200 W motor – powerful but quiet

**FILTER SYSTEM**

Active HEPA filter

4.5 litre self-sealing dustbag – Type GN

**FEATURES**

Stainless steel height adjustable telescopic suction tube

Standard floorhead SBD 285-3 with retractable brushes for edge to edge cleaning of carpets and hard floors and 360° comfort swivel joint  
Operating radius 10 m

Park system for floorhead at rear of cleaner  
Storage system at either side for easy carrying  
Automatic cable rewind with comfort touch

**SAFETY**

Bumper strip to protect cleaner and furniture  
Change dustbag indicator  
Automatic cut-out on overheating

S 5360 Cat &amp; Dog 2200 – Titan Red Metallic



Designed and tested for an average life of 20 years

**CONTROLS**

Electronic suction power regulation using rotary dial

6 power settings including "Silence" setting

**PERFORMANCE**

2200 W motor – powerful but quiet

**FILTER SYSTEM**

Active Air Clean filter

4.5 litre self-sealing dustbag – Type GN

**FEATURES**

Stainless steel height adjustable telescopic suction tube

Standard floorhead SBD 550-3 with retractable brushes for edge to edge cleaning of carpets and hard floors and 360° comfort swivel joint  
Full size Turbobrush STB 205-3

Socket for Miele Electrobrush  
Operating radius 10 m  
Park system for floorhead at rear of cleaner with automatic on/off switch  
Storage system at either side for easy carrying  
Automatic cable rewind with comfort touch

**SAFETY**

Bumper strip to protect cleaner and furniture  
Change dustbag indicator  
**Automatic cut-out on overheating with indicator light**

S 5380 Solution HEPA 5000 – Marine Blue Velvet



Designed and tested for an average life of 20 years

**CONTROLS**

Electronic suction power regulation using rotary dial

6 power settings including "Silence" setting

**PERFORMANCE**

2200 W motor – powerful but quiet

**FILTER SYSTEM**

Active HEPA filter

4.5 litre self-sealing dustbag – Type GN

**FEATURES**

Stainless steel height adjustable telescopic suction tube

Standard floorhead SBD 550-3 with retractable brushes for edge to edge cleaning of carpets and hard floors and 360° comfort swivel joint  
Parquet brush SBB 300-3

Full size Turbobrush STB 205-3  
Socket for Miele Electrobrush  
Operating radius 10 m  
Park system for floorhead at rear of cleaner with automatic on/off switch  
Storage system at either side for easy carrying  
Automatic cable rewind with comfort touch

**SAFETY**

Bumper strip to protect cleaner and furniture  
Change dustbag indicator  
**Automatic cut-out on overheating with indicator light**

**STB 205 Turbobrush**



- Rotating roller brush
- Buffer strip around the turbobrush protects furniture from scuffing

**STB 101 Mini Turbobrush**



- For vacuuming cut pile stair carpets and removing dust and pet hairs from upholstery

**MicroSet SMC 10**



- Designed for fiddly nooks and crannies such as PC keyboards, stereo equipment, intricately carved furniture and ornaments

**CarClean Set SSC Vario**



- Extra long crevice nozzle (30 cm) for getting between the seats and inside compartments

**SBB 300-3 Parkett**



- New Parquet brush, which has a 90° rotational action enabling easy access around obstacles such as table legs, etc.

**Floorbrush SBB Parkett**



- Specially designed for parquet, floorboards and tiled floors

**Dust bags F/J/M Plus**

For models S 300/500/700/4000



- 5 dust bags in a box and contains a super air clean filter and a dust compartment filter

**Dustbags G/N Plus**

For models S 400/600/800/5000



- 5 dust bags in a box and contains a super air clean filter and a dust compartment filter

**SMD 10 Mattress Nozzle**



- Ideally suited to reaching between the mattress and the bedstead or between the cushions of upholstered furniture

**SEB 216-2 Electrobrush**



- Recommended for thorough cleaning of carpets subjected to heavy use and likely to suffer from tread
- Electrically driven with own motor, ensures constant brush rotation

**Active Hepa Filter**



- Conforms to European standard EN 1822
- Trapping particles as small as 0.3 of a micron (i.e. particles such as dust mite faeces and tobacco smoke)
- Hold advantages of charcoal filter
- Designed and tested for 50 working hours or 12 months

**Active Air Clean Filter**



- Combination of the super air clean filter with an active charcoal filter
- Absorbs odours from the dust bag – especially useful for families with pets
- Designed and tested for 50 working hours or 12 months

Model no.		W 1513	W 526	W 3240	W 3364	W 3574 WPS	W 3923 WPS	W 3985	WT 2670
<b>Features</b>									
Unique Miele Honeycomb drum		–	–	•	•	•	•	•	•
<b>Controls</b>									
Fully Electronic Novotronic / Navitronic Controls		–	–	•/–	•/–	•/–	•/–	– /•	•
Sensor load size indicator		–	–	–	–	–	–	•	•
Automatic detergent dose recommendation		–	–	–	•	–	–	•	•
Spin Speed (Maximum)		1300	1400	1400	1600	1600	1600	1800	1600
Program sequence LEDs		–	6	6	6	7	•	Display	Display <sup>2)</sup>
<b>Dimensions and Weight</b>									
Capacity – washing	kg	5	5	6	6	6	6	6	5
Capacity – drying	kg	–	–	–	–	–	–	–	2.5
Height	cm	85	85	85	85	85	85	85	85
Width	cm	59.5	59.5	59.5	59.5	59.5	59.9	59.5	59.5
Depth (including distance from wall) / with door open	cm	63.4/107.4	58/97.5	58/97.5	58/97.5	58/97.5	58/97.5	58	60/97
Weight	kg	99	93	95	94	94	94	94	99
Stacked height (with matching dryer)	cm	170/172	170/172	170/172	170/172	170/172	169/170	170/172	–
<b>Performance / Consumption data <sup>1)</sup></b>									
Water consumption	liters	45	45	49	49	69	47	47	56+9 <sup>3)</sup>
Electricity consumption	kWh	0.85	0.85	1.02	0.85	1.14	1.02	1.02	2.4 <sup>3)</sup>
Standard programme duration <sup>4)</sup>	min	109/59	116/59	109/59	109/59	127/58	116/59	109/59	160 <sup>5)</sup>
Residual moisture level		50%	50%	50%	44%	44%	44%	43%	44%
<b>Electricity and Water Connections</b>									
Fuse rating / Total rated load	A / kW	13/ –	13/2.4	13/2.4	13/ –	13/2.4	13/2.4	13/2.4	13/2.7
Water inlet hose	m	1.6	1.6	1.6	1.6	1.6	1.6	1.6	1.6
Drain connection hose	m	1.5	1.5	1.5	1.5	1.5	1.5	1.5	1.5

• = yes, existing

<sup>1)</sup> According to EN 60456 tested in Cottons 60°C Intensive with a 5 kg load

<sup>2)</sup> Including drying process

<sup>3)</sup> Washing & drying cycle – According to EN 60456 and EN 61121 tested in Cottons 60°C and Cottons Normal (washload 5 kg, dryload 2.5 kg)

<sup>4)</sup> Cottons 60°C Normal, 5 kg load / Delicates 30°C Normal, 1 kg load

<sup>5)</sup> Washing & drying 2.5 kg

Model no.		T 7634C	T 4162	T 4262 C	T 4462 C	T 4464 C	T 8623 C	T 8685C
<b>Features</b>								
Unique Miele Honeycomb drum		–	•	•	•	•	•	•
Fuzzy logic sensitive drying system		•	•	•	•	•	•	•
Automatic moisture sensor drying		•	•	•	•	•	•	•
Easy Clean fluff filter		•	•	•	•	•	•	•
<b>Controls</b>								
Fully Electronic Novotronic / Navitronic Controls		•/–	•/–	•/–	•/–	•/–	•/–	–/•
“Favourites” – memory and shortcut buttons		•/•	–	–	–	–	–	•
<b>Dimensions and Weight</b>								
Capacity	kg	6	6	6	6	6	6	6
Height	cm	85	85	85	85	85	85	85
Width	cm	59.5	59.5	59.5	59.5	59.5	59.9	59.5
Depth (including distance from wall) / with door open	cm	63.4/107.4	58/106	58/106	58/106	58/106	58/106	58/106
Weight	kg	46	48	54	54	54	54	54
Stacked height (with matching washing machine)	cm	170/172	170/172	170/172	170/172	170/172	170/172	170/172
<b>Electrical connection</b>								
Fuse rating / Total rated load	A / kW	13/–	13/2.7	13/2.85	13/2.85	13/2.85	13/–	13/–
Drain connection	m	–	–	2	2	2	1.5	1.5
Maximum drain pump height / length	m	–	–	1/3	1/3	1/3	4	1.5/4
<b>Performance / Consumption data <sup>1)</sup></b>								
Electricity consumption	kWh	2.75	2.9	3.05	2.9	2.95	2.85	2.85
Programme duration	min	68	81	91	83	83	78	78

• = yes, existing

<sup>1)</sup> For Cotton Normal spun at 1400 rpm (50% residual)

Model no.		G 975	G 1040	G 1140SC	G 1220 SC	G 1230 SC
<b>Design</b>						
Width	cm	60	60	60	60	60
Freestanding		•	•	•	•	•
Colours		white	white	white	white	stainless steel
<b>Controls</b>						
Fully Electronic Novotronic controls		•	•	•	•	•
Single Dial Control / Button touch controls		•/-	•/-	-/•	-/•	-/•
Delay Start		-	-	-	•	•
<b>Maximum sound level (re 1pW)</b>		51 dB	48 dB	48 dB	48 dB	48 dB
<b>Consumption data <sup>1)</sup> for Economy / Normal 50°C</b>						
Energy efficiency class <sup>2)</sup>		A	A	A	A	A
Wash performance class <sup>2)</sup>		A	A	A	A	A
Drying performance class <sup>2)</sup>		A	A	A	A	A
Water consumption	liters	13	13/13-22	13/13-22	13/13-22	13/13-22
Energy consumption	kWh	1.05	1.05/1-1.4	1.05/1-1.4	1.05/1-1.4	1.05/1-1.4
Program duration	min	168	176/105-145	176/105-145	176/85-142	176/85-142
<b>Programs</b>		6	6	6	6	6
<b>Features</b>						
Turbothermic plus drying		•	-	•	•	•
Triple filter system		•	•	•	•	•
ECO Sensor / Auto Sensor		-	•/-	•/-	-/•	-/•
<b>Capacity</b>						
International place settings		12	12	12	12	12
Plate diameter, upper basket		15-19	23	15-19	15-19	15-19
Plate diameter, lower basket		26-30	28	26-30	27-31	27-31
<b>Installation</b>						
Height (adjustable)	cm	84.7-88.7	84.5-88.0	84.5-88.0	84.5-88.0	84.5-88.0
Width	cm	59.8	59.8	59.8	59.8	59.8
Depth	cm	60	60	60	60	60
Weight	kg	60	59	59	59	59
Fuse rating / Total rated load	A / kW	230 V to 240 V, 50 Hz. fuse rating 13 A				
Water connection		1.5 m waterproof double hose with 19 mm (3/4 inch) threaded union				
Water supply		Cold or hot. max 60°C; 0.3 to 10 bar (30 to 1000 kPa)				
Drain connection		1.5 m flexible drain hose, internal diameter 22 mm (7/8 inch)				
Maximum drain pump height/length		1 m/4 m	1 m/4 m	1 m/4 m	1 m/4 m	1 m/4 m

• = yes, existing

<sup>1)</sup> Connected to 15°C cold water supply

<sup>2)</sup> According to EN 50242 using standard program Economy

Model no.		DG 1050
<b>Design</b>		
Door hinged right/left		-/•
<b>Dimensions and weight</b>		
Height	cm	38.2
Width	cm	49.5
Depth	cm	32.7
Weight	kg	19.3
<b>Features</b>		
Shelf levels		3
Cooking containers		2
Water container		1
Permanent water connection		-
<b>Controls</b>		
IC display / with clear text		•/•
Rotary switches		1
<b>Cooking functions</b>		
Cooking settings		-
Temperature control	°C	40-100
Programmable cooking times		•
<b>Electrical connection</b>		
Fuse rating / Total rated load	A / kW	13/2.2

Model no.		CVA 2650
<b>Design</b>		
Door hinged right/left		-/•
<b>Dimensions and weight</b>		
Height	cm	38.0
Width	cm	49.
Depth	cm	34.0
Weight	kg	25.0
<b>Features</b>		
Freshwater container	l	1.5
Steam spout / Milk frother		•
Water container		•
Capsule container		•
<b>Controls</b>		
Programmable water quantity per cup	ml	30-175
LC display / with clear text		•/•
Rotary switches		2
Language programmable		•
Stand-by function with timer		•
Indicators		•
<b>Electrical connection</b>		
Fuse rating / Total rated load	A / kW	13/2.3

Model no.		M 8201
<b>Appliances Dimension</b>		
Height	cm	30.5
Width	cm	52
Depth	cm	42.2
Volume	l	26
<b>Buildings in dimension</b>		
Height	cm	20.7
Width	cm	34.2
Depth	cm	36.8
Weight	kg	16.5
<b>Specifications</b>		
no. of power levels		
Power output levels	W	80/150/300/ 450/600/ 750/900
Browning element	W	800
No. of automatic		10 s-90 min
<b>Electrical connection</b>		
Fuse rating / Total rated load	A / kW	13/2.05

Model no.		K 8852 SD	K 8952 SDed-1	FN 4857 S	FN 4957 Sed-1	KFN 8452 SD
<b>Type of appliance</b>						
Freestanding		•	•	•	•	•
Door hinged r = right, c = convertible, l = left		r/c	r/c	l/c	l/c	r/c
Compressors*		1	1	1	1	1
<b>Star marking <sup>1)</sup></b>						
Type of climate <sup>2)</sup>		SN-T	SN-T	SN-T	SN-T	SN-T
<b>Dimensions and weight</b>						
Height	cm	184.1	184.1	184.1	184.1	180.6
Width	cm	60	60	60	60	60
Depth inc distance from the wall <sup>3)</sup>	cm <sup>3</sup>	63.2	63.2	63.2	63.2	63.2
Net weight	kg	79.7	78.9	80.5	78.4	77.5
<b>Capacities</b>						
Net fridge capacity	litres/cu ft	398/14.1	398/14.1	–	–	224/7.9
Net stay fresh capacity	litres/cu ft	–	–	–	–	–
Net freezer capacity	litres/cu ft	–	–	257/9.1	257/9.1	89/3.1
Net wine cooler capacity	litres/cu ft	–	–	–	–	–
<b>Defrosting procedure</b>						
Fridge		Automatic	Automatic	–	–	Automatic
Freezer		–	–	Automatic	Automatic	Automatic
<b>Electrical connection</b>						
Fuse rating / Total rated load	A / kW	13/0.13	13/0.13	13/0.259	13/0.259	13/0.13
<b>Energy consumption <sup>4)</sup></b>						
Per year		182.5	183	328.5	328.5	376
Energy efficiency rating		A	A	A	A	A
Complies with safety regulations		•	•	•	•	•

• = yes, existing

<sup>1)</sup> ❄️ = frozen food storage compartment with -18°C

<sup>2)</sup> SN = suitable for normal climate with surrounding temperatures of 10°C to 32°C

N = suitable for surrounding temperatures of 16°C to 32°C

SN-T = suitable for surrounding temperatures of 10°C to 43°C

SN-ST = suitable for surrounding temperatures of 10°C to 38°C

<sup>3)</sup> Depth includes the curve on the door on freestanding softline models

<sup>4)</sup> Energy consumption per year was calculated according to DIN EN 153 1990. Tests were made on a 220 V/50 Hz appliance.

Model no.		KTN 4352 Sded	KF 8582 Sded	KFN 8562 SD ED	KFN 8701 SEed-1	KWFN 8706 SEed-1
<b>Type of appliance</b>						
Freestanding		•	•	•	•	•
Door hinged r = right, c = convertible, l = left		r/c	r/c		l/c	l/c
Compressors*		1	1	1	2	2
<b>Star marking <sup>1)</sup></b>						
Type of climate <sup>2)</sup>		SN-T	SN-T	SN-T	SN-T	SN-T
<b>Dimensions and weight</b>						
Height	cm	169	184	184	184.1	184.1
Width	cm	60	75	60	60	60
Depth inc distance from the wall <sup>3)</sup>	cm <sup>3</sup>	63	63	63.2	63.2	63.2
Net weight	kg	74	102		92.9	87.9
<b>Capacities</b>						
Net fridge capacity	litres/cu ft	224/7.9	337/11.9	224/7.9	-	-
Net stay fresh capacity	litres/cu ft	-	-	-	130/4.5	-
Net freezer capacity	litres/cu ft	60/2.1	95/3.3	89/3.1	119/4.1	119/4.1
Net wine cooler capacity	litres/cu ft	-	-	-	-	144/5.0
<b>Defrosting procedure</b>						
Fridge		Automatic	Automatic	Automatic	Automatic	Automatic
Freezer		Automatic	Manual	Automatic	Automatic	Automatic
<b>Electrical connection</b>						
Fuse rating / Total rated load	A / kW	13/0.14	13/0.14	13/0.13	13/0.17	13/0.17
<b>Energy consumption <sup>4)</sup></b>						
Per year		328.5	321	376	379.6	343.1
Energy efficiency rating		A	A+	A	A	A
Complies with safety regulations		•	•	•	•	•

• = yes, existing

<sup>1)</sup> \* = frozen food storage compartment with -18°C

<sup>2)</sup> SN = suitable for normal climate with surrounding temperatures of 10°C to 32°C

N = suitable for surrounding temperatures of 16°C to 32°C

SN-T = suitable for surrounding temperatures of 10°C to 43°C

SN-ST = suitable for surrounding temperatures or 10°C to 38°C

<sup>3)</sup> Depth includes the curve on the door on freestanding soffline models

<sup>4)</sup> Energy consumption per year was calculated according to DIN EN 153 1990. Tests were made on a 220 V/50 Hz appliance.

Model no.		KWL 4712 SGed	KWT 4974 SGed	KWFN 8996 SDEed-1	KFNS 3929 Sed
<b>Type of appliance</b>					
Freestanding		•	•	•	•
Door hinged r = right, c = convertible, l = left		r/c	r/c	r/c	–
Compressors*		1	1	2	3
<b>Star marking <sup>1)</sup></b>					
Type of climate <sup>2)</sup>		SN-ST	SN-ST	SN-T	SN-T
<b>Dimensions and weight</b>					
Height	cm	165.8	185.5	200	187
Width	cm	66	66	75	121
Depth inc distance from the wall <sup>3)</sup>	cm <sup>3</sup>	68.3	67.4	63	68.4
Net weight	kg	82	97	115	–
<b>Capacities</b>					
Net fridge capacity	litres/cu ft	–	–	320/11.3	237/11.9
Net stay fresh capacity	litres/cu ft	–	–	–	100/3.5
Net freezer capacity	litres/cu ft	–	–	119/4.2	119/4.2
Net wine cooler capacity	litres/cu ft	386/13.6	386/13.6	–	144/5.1
<b>Defrosting procedure</b>					
Fridge		Automatic	Automatic	Automatic	Automatic
Freezer		–	–	Automatic	Automatic
<b>Electrical connection</b>					
Fuse rating / Total rated load	A / kW	13/0.12	13/0.12	13/0.23	13 x 2 / 0.13 + 0.17
<b>Energy consumption <sup>4)</sup></b>					
Per year		178	332	464	533
Energy efficiency rating		–	–	A	A
Complies with safety regulations		•	•	•	•

• = yes, existing

<sup>1)</sup> **\*\*\*\*** = frozen food storage compartment with -18°C

<sup>2)</sup> SN = suitable for normal climate with surrounding temperatures of 10°C to 32°C

N = suitable for surrounding temperatures of 16°C to 32°C

SN-T = suitable for surrounding temperatures of 10°C to 43°C

SN-ST = suitable for surrounding temperatures of 10°C to 38°C

<sup>3)</sup> Depth includes the curve on the door on freestanding softline models

<sup>4)</sup> Energy consumption per year was calculated according to DIN EN 153 1990. Tests were made on a 220 V/50 Hz appliance.

Model no.		S 4211	S 4211 Parquet & Co	S 5210	S 5280	S 5360	S 5380
<b>Features &amp; Equipment</b>							
Colour		Lemon Yellow	Electric Blue Metallic	Deep Black	Silver Metallic	Titan Red Metallic	Marine Blue Velvet
Controls		Rotary Dial	Rotary Dial	Rotary Dial	Rotary Dial	Rotary Dial	Rotary Dial
Operating radius	m	9	9	10	10	10	10
Usable dust bag volume	l	3.5	3.5	4.5	4.5	4.5	4.5
Suction power control: Electronic / via ir vent		•/–	•/–	•/–	•/–	•/–	•/–
Dust bag change indicator		•	•	•	•	•	•
Sound insulation: Standard / Silence		•/–	•/–	•/•	•/•	•/•	•/•
Intensive Clean dust bag type		F/J/M Plus	F/J/M Plus	GN–2	GN–2	GN–2	GN–2
Super AirClean filter		•	•	•	–	–	–
Active AirClean filter		–	–	–	–	•	–
Active HEPA filter		–	–	–	•	–	•
“Change filter” indicator		–	–	–	–	–	–
Thermal safety cut-out indicator		•	•	•	•	•	•
Park system on / off		–	–	–	–	–	•
Cable rewind: Manual / Auto remove		•/–	•/–	–/•	–/•	–/•	–/•
Socket for Electro Brush SEB 216-2		–	–	–	–	–	•
Hose coupling shutter		–	–	–	–	•	–
<b>Accessories supplied as standard</b>							
Stainless steel suction tube <sup>1)</sup>		b	c	b	b	b	b
Smooth running floor head		SBD 450–3	SBD 450–3	SBD 285–3	SBD 285–3	SBD 550–3	SBD 550–3
Allergotec floor head		–	–	–	–	–	–
Turbo brush		–	–	–	–	STB 205–3	STB 205–3
Dusting brush		–	•	•	•	•	•
Upholstery nozzle		•	•	•	•	•	•
Crevice nozzle / crevice nozzle extension		•/–	•/–	•	•	•	•
Parquet floor brush		–	SBB Parquet–3	–	–	–	SBB 300–3
Mattress nozzle		–	–	–	–	–	–
<b>Electrical connection</b>							
Max. rated load	W	2000	2000	2200	2200	2200	2200

• = yes, existing

<sup>1)</sup> a = two-piece

b = telescopic

c = triscopic



**Miele Ireland Limited**  
Broomhill Business Complex  
Broomhill Road  
Tallaght  
Dublin 24  
Tel.: +353 (0)1 461 0710  
Fax: +353 (0)1 461 0797  
[www.miele.ie](http://www.miele.ie)  
[info@miele.ie](mailto:info@miele.ie)

